



ENERGY RECOVERY FANS
Tempero





ENERGY RECOVERY FANS

Tempero

- Fan provided with an energy recovery system
- Ideal for domestic applications
- Suitable for single room application
- Wall and/or panel application
- Body in white ABS with inner components in polypropylene
- Cross Flow Air Exchanger welded PVC plates
- Two centrifugal fans with sleeve bearings motors
- Filters in polyurethane to grant higher protection and longer function
- Every model equipped with "operating warning light"
- Pre-heating system (PH model only) consists of a 350 W coil with thermostat, fitted in a box of self extinguishing material.
- Single speed
- 3 models available: Basic, Timer and Pre-heater for cold climates
- In accordance with EN 60335-2-80
- High performance in terms of balance between energy recovery, consumption, flow rate and noise level

Tempero 100

"Basic version" suitable for climates and temperatures between -5°C and $+35^{\circ}\text{C}$.

Tempero 100 T

Same main features of the basic version with added Timer control.

Tempero 100 PH

Suitable for outdoor minimum temperatures of: -25°C .

Dimensions

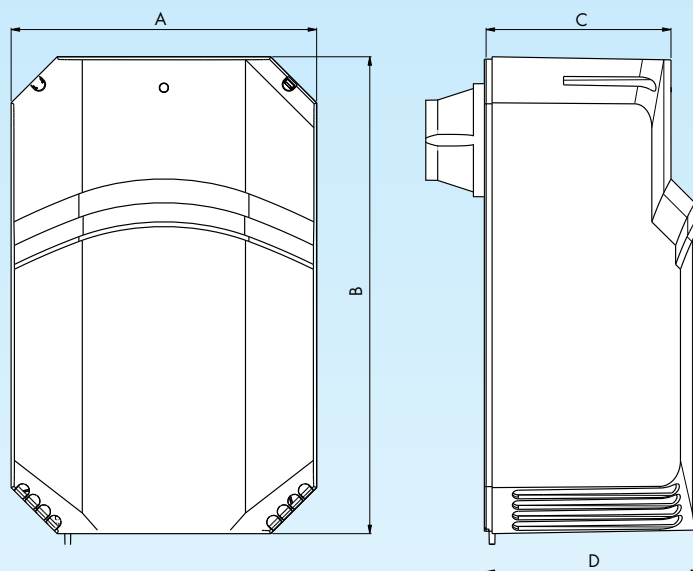

CE

IPX4



No Tempero
100 PH



Model	A	B	C	D
TEMPERO 100	257	400	155	179
TEMPERO 100T	257	400	155	179
TEMPERO 100PH	257	400	155	179

Technical data

Model	Ref.	INTAKE m ³ /h	EXTRACT m ³ /h	dB(A) 3 m	Weight Kg	Hz	W	Eff. (%)	Temp °C	Ø hole mm	Nom Volt
100	OW 684 3	60	70	34	3,3	50Hz	40	70	-5 +35	100/120	220/240
100T	OW 685 0	60	70	34	3,3	50Hz	40	70	-5 +35	100/120	220/240
100PH	OW 686 8	60	70	34	3,3	50Hz	400	70	-25 +35	100/120	220/240



ENERGY RECOVERY FANS

Tempero

Tempero is an extractor fan provided with an energy recovery system ideal for single room domestic applications.

It offers healthier and better indoor environment by moderating the temperature of the incoming air plus economic advantages due to energy saving.

The flow of extracted air transfers thermal energy to the fresh incoming air, first through the surface of the internal ducting pipe fitted into the existing duct and then through the "cross flow plates" heat recovery core located in the unit. During this process the incoming and outgoing air flows are completely separated.

During winter season, **Tempero** guarantees an efficient energy recovery of up to 70%.

During summer season, **Tempero** reduces substantially the energy required for air conditioning.

Suitable for wall applications, it can be easily fitted to 100 and 120 mm new or existing ducts, offering the opportunity to renovate, substituting old/non functioning axial fans without further invasive procedures to the building structure.

The heat recovery core of PVC cross flow plates is equipped with two easily removable filters for simple and regular cleaning.

Tempero has been conceived and designed to work as a usual air extractor fan with the advantage of added energy conservation.

In normal conditions **Tempero** will not produce enough condensation to require drainage.

It has been equipped with a dedicated condensation drainage hole thus eliminating the build up of excess condensation related to the certain environmental conditions (temperature, humidity ...) and/or continuous use.

Tempero has been designed to work also in cold climates of -25°C , thanks to a pre-heating coil available for the PH model only.

The **Tempero** PH model pre-heater, is a 350 W coil fitted in the ducting pipe. When the outside temperature falls below -5°C a thermostat activates the coil thus heating incoming air to about $15-20^{\circ}\text{C}$ avoiding ice build-up on the recovery module.

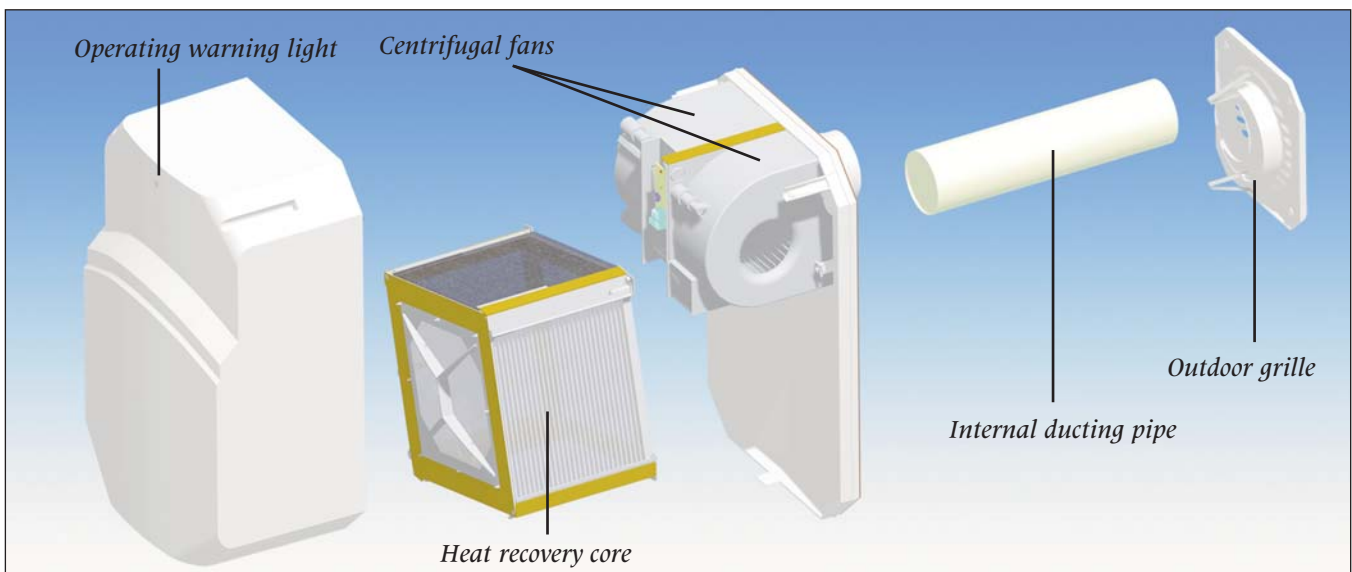



ENERGY RECOVERY FANS

Tempero



Extracted air stream transfers thermal energy to the fresh incoming air, first through the surface of the PVC ducting pipe and of the motors' heat and then through the "cross flow plates" heat recovery core located into the unit.

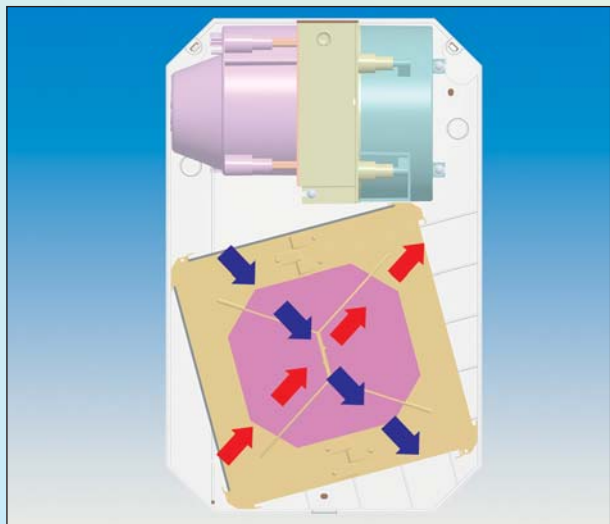

Tempero can be easily installed on new or existing ducts (diameter 100/200 mm).

Possibility of renovating old/non functional fans thus granting a healthier and better indoor environment with minimal or no invasive procedure to the building structure.

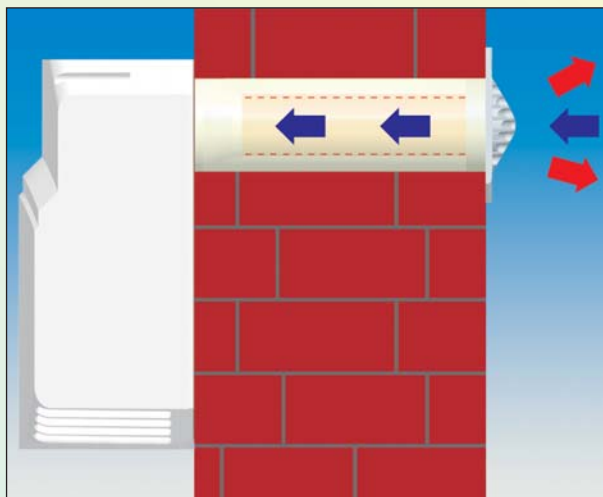

Tempero is supplied with a PVC ducting pipe (diameter: 63mm), which should be fitted internally to the existing duct (diameter 100/120 mm) up to a maximum wall depth of 400 mm. If the depth of wall exceeds 400 mm a replacement pipe is required.

Timer and (PH) operations

Timer

When switched on, the fan will start rotating after 5 seconds and will overrun after being switched off according to the pre-set overrun timer period. Adjustable overrun timer from 2 min. up to 30 min. Standard setting: 15 min.

Pre-heater (PH)

The PH model is equipped with a pre-heating system, consisting of a 350 W coil fitted into the PVC ducting pipe and activated by a thermostat. Starting with an outside temperature lower than -5°C incoming air will be heated-up to about $15-20^{\circ}\text{C}$ thus avoiding ice build-up on the recovery module and granting the highest levels of efficiency.